



# AF SERIES

*Aluminum Compressed Air Filters*

**MODEL RANGES 35 – 450 SCFM**

<b>Operating Pressure</b>	<b>232 PSIG</b>
<b>Volume Flow Rate</b>	<b>35 – 450 SCFM</b>
<b>Operating Temperature Range</b>	<b>35 – 149 F</b>
<b>Connections</b>	<b>3/8" – 1 1/2" NPT-F</b>

## DESCRIPTION

AF filter housings are designed for high efficient removal of solid particles, water, oil aerosols, hydrocarbons, odor and vapors from compressed air systems. To meet the required compressed air quality for your needs, we offer a variety of filter elements (P, R, S, A, A2, MS2) that are interchangeable with the AF filter housing.

## APPLICATIONS

- general industrial applications
- automotive
- electronics
- food and beverage
- chemical
- petrochemical
- plastics
- paint



**COMPRESSED AIR FILTERS**

**COMPRESSED AIR SPECIALIST**

## Technical Specifications

Filter Housing Size	Pipe Size Inches	Max Operating Pressure PSIG	Flow Rate At 100 PSIG 68 Degrees F	Dimensions (Inches)				Weight (Pounds)
				A	B	C	D	
AF 35	3/8"	232	35	7.36	3.46	0.78	2.36	1.54
AF 45	1/2"	232	45	7.36	3.46	0.78	2.36	1.54
AF70	3/4"	232	70	10.11	3.46	0.78	3.14	1.76
AF115	1"	232	115	10.35	4.92	1.25	3.93	3.96
AF200	1"	232	200	14.29	4.92	1.25	4.72	5.51
AF 300	1 1/2"	232	300	18.14	4.92	1.25	5.51	5.51
AF 450	1 1/2"	232	450	25.19	4.92	1.25	6.29	7.05

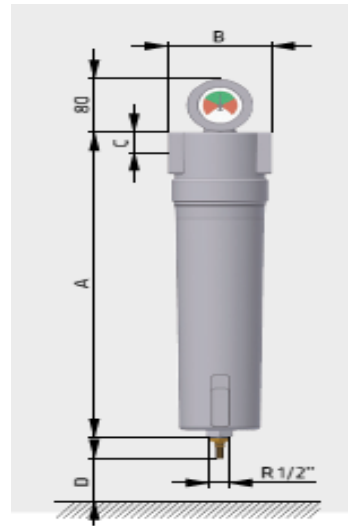

## Filter Elements

Filter Model	P Prefilter 3 Micron	R Prefilter 1 Micron	S Prefilter 0.01Micron	A Activated Carbon	A2 Adsorption With Activated Carbon	MS2 Molecular Sieve
AF 35	AP35E	AR35E	AS35E	AA35E	AA235E	MS235E
AF 45	AP45E	AR45E	AS45e	AA45E	AA245E	MS245E
AF70	AP70E	AR70E	AS70E	AA70E	AA270E	MS270E
AF115	AP115E	AR115E	AS115E	AA115E	AA2115E	MS2115E
AF200	AP200E	AR200E	AS200E	AA200E	AA2200E	MS2200E
AF 300	AP300E	AR300E	AS300E	AA300E	AA2300E	MS2300E
AF 450	AP450E	AR450E	AS450E	AA450E	AA2450E	MS2450E
Quality Class – Solids ( ISO 8573-1)	6	3	1	1	1	1
Residual Oil Content	n/a	n/a	<0.01	<0.005	<0.005	n/a
Quality Class – Oils ( ISO 8573-1)	n/a	n/a	1	1	0/1	n/a
Pressure Drop New Element / PSI	0.145	0.29	1.16	0.87	See Spec	0.725
Change Element Pressure Drop / PSI	5.07	5.07	5.07	6 months	6 months	
Filter Element Material	Acrylic Fibers Cellulose	Borosilicate Micro Fibers	Borosilicate Micro Fibers	Borosilicate Micro Fibers Activated Carbon	Borosilicate Micro Fibers Activated Carbon	Borosilicate Micro Fibers Molecular Sieve
Pleated Version	X	X	X		X	X
Wrapped Version				X		
Minimum Operating Temperature / F	35	35	35	35	35	35
Maximum Operating Temperature / F	149	149	149	149	149	149

## Correction Factors

Operating Pressure (PSI)	29	44	58	72	87	100	115	130	145	160	174	189	203	218	232
Correction Factor	0.38	0.5	0.63	0.75	0.88	1	1.13	1.25	1.38	1.50	1.63	1.75	1.88	2.00	2.13

<sup>1</sup> B filter element can be cleaned with ultrasonic bath or with back flushing. Intervals of cleaning depends of application. If necessary replace filter element with new one.

<sup>2</sup> Filter elements "A, A<sup>2</sup>, H<sup>2</sup>", must be changed periodically to suit application, but at least every 6 months. Activated carbon filters must not operate in oil saturated conditions.

<sup>3</sup> Valid if "S" filter cartridge is installed upstream.

<sup>4</sup> For elements A<sup>2</sup>, H<sup>2</sup> and MS<sup>2</sup> it is necessary to reduce the flow according to technical data sheet specification.