



NORTHEAST
PNEUMATICS

INTELLI-DRAIN

Intelligent Electronic Drain



Zero Air Loss Condensate Drain

FEATURES

- Designed for Filters
- Zero Air Loss
- Compact in Size
- Capacitive Level Sensor
- LED Indicator
- Manual Test Button
- Discharges Over 2 Gallons / Hour

Description

The Intelli-Drain is an electronic zero air loss drain that has been designed for fully automatic discharge of condensate or any other nonaggressive fluids from compressed air systems. The Intelli-Drain is compact in design and primarily used on filter housings. Operation is simple! As condensate accumulates in the bottom of the filter housing the condensate level is detected by the precise capacitive level sensor. When the condensate level is high enough the condensate is then discharged from the system without any air loss. Intelli-Drain is also equipped with a led indicator and manual test button to check drain operation.

COMPRESSED AIR SPECIALIST

INTELLIGENT ELECTRONIC DRAIN

Application

Filters Housings



Operating Conditions

Operating Pressure Range	0 – 232 PSIG
Drain Capacity	2.11 Gal / Hour
Connection Port	1/2"
Operating Temperature Range	35 - 150

Technical Data

Technical Data	Intelli-Drain
Voltage	115/50-60/1
Internal Fuse	5 x 20 1A T
Power Consumption	10 VA
Operating Pressure Range	0 – 232 PSIG
Operating Temperature Range	35 – 150 F
Inlet Connection	1/2" Parallel Thread
Outlet Connection	5/16" Push Connector
Drain Capacity	2.11 Gallons / Hour
Protection Class	IP54
Weight	10.58 ounces

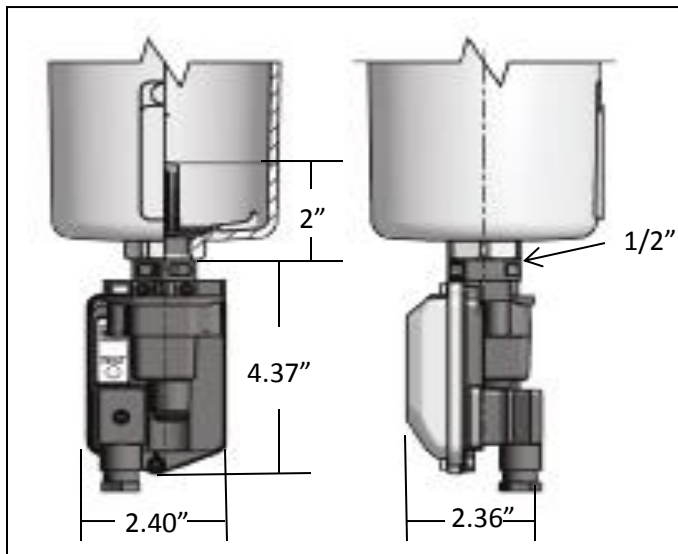

TECHNICAL SPECIFICATION